

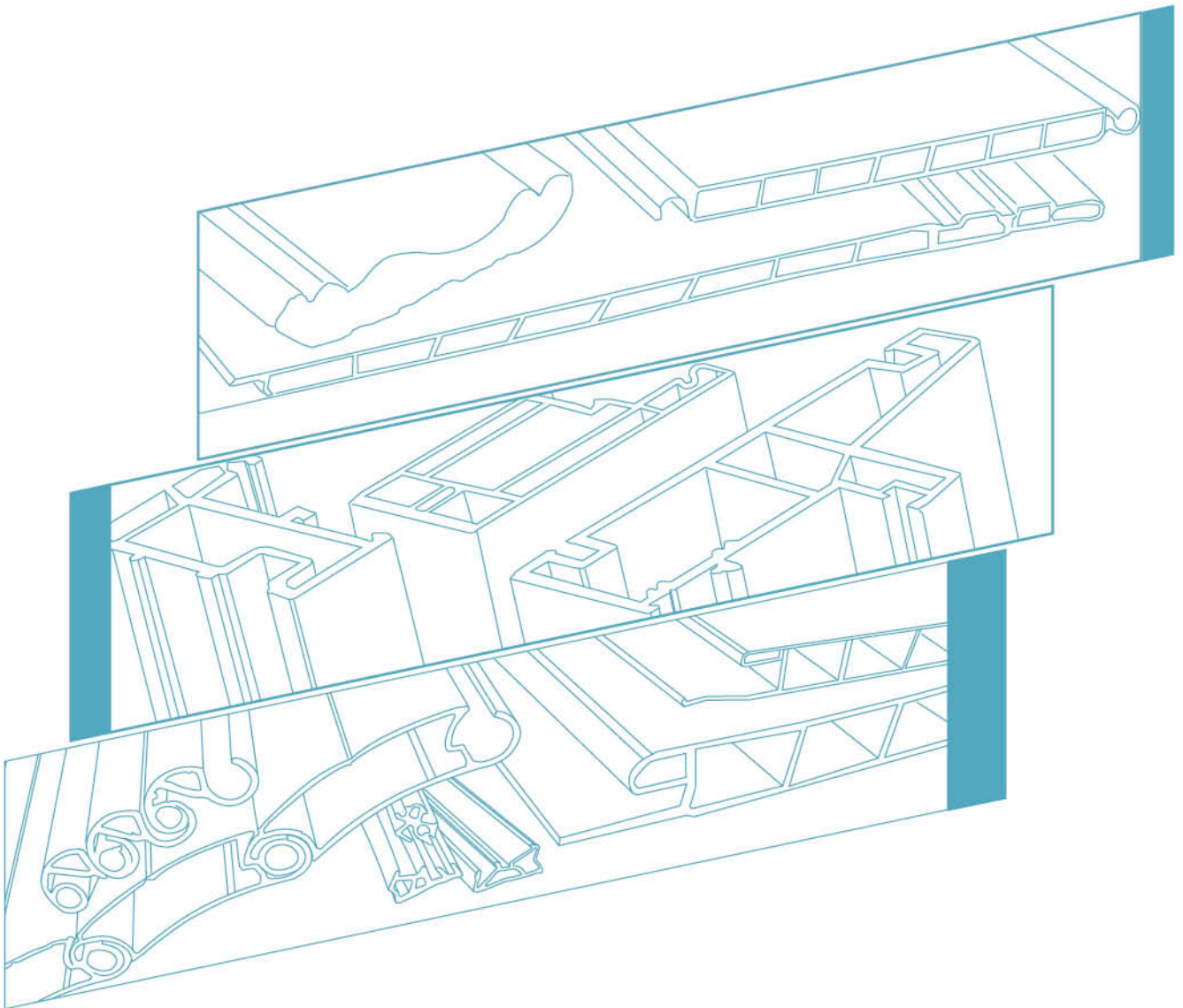

Everplast

PROFILE EXTRUSION MACHINE



we offer turnkey and total solution



➤ PROFILE PRODUCTION LINE



3 Color Printing Machine

The profile processing introduction for extruding machinery will show how extruded products meet the needs of the market as well as the special characteristics of the plastics that are used and the efficient assembling uses in the production process. Materials that can be used for extrusion include PVC, HDPE, LDPE, PE, PP, ABS PS, PC and PMMA.

Products manufactured with these machines include construction materials, toys and stationery, furniture and furnishings, medical supplies, lighting decoration and electrical accessories. Since its founding EVERPLAST Machinery's production line has turned out more than 1500 extrusion systems over the years. The suitability of these products and their competitiveness on the market are directly related to the characteristic of the plastic materials involved and the processes and machine fittings used to make the extrusion products.



Mixer and Cooler

➤ EXTRUSION MACHINE

PVC counter rotation twin screw extruder available in sizes of EMD-65, EMD-90, EMD-110 and EMD-130 for profile and compounding , output ranges from 100 to 800 KGS/HR.

Single screw extruder comprises model EMS-35,45,55,65,85,100,120 and 150 to meet a wide range of requirements for extrusion types, materials, and application.

Precision grinding gears deliver a driving force that is more than 98 percent accuracy with noise levels under 65 dB.

“PID” thermo controller with “SCR” output temperature systems are used throughout to minimize power consumption and maintain temperature levels which are within one degree of set temperatures.

Along with cast aluminum cooling device on the barrel, and high efficiency driving motor and gears. That ensure consistent products and high outputs.

Optional extras:

- Computer controller system.
- P.T.A Treatment for screw.

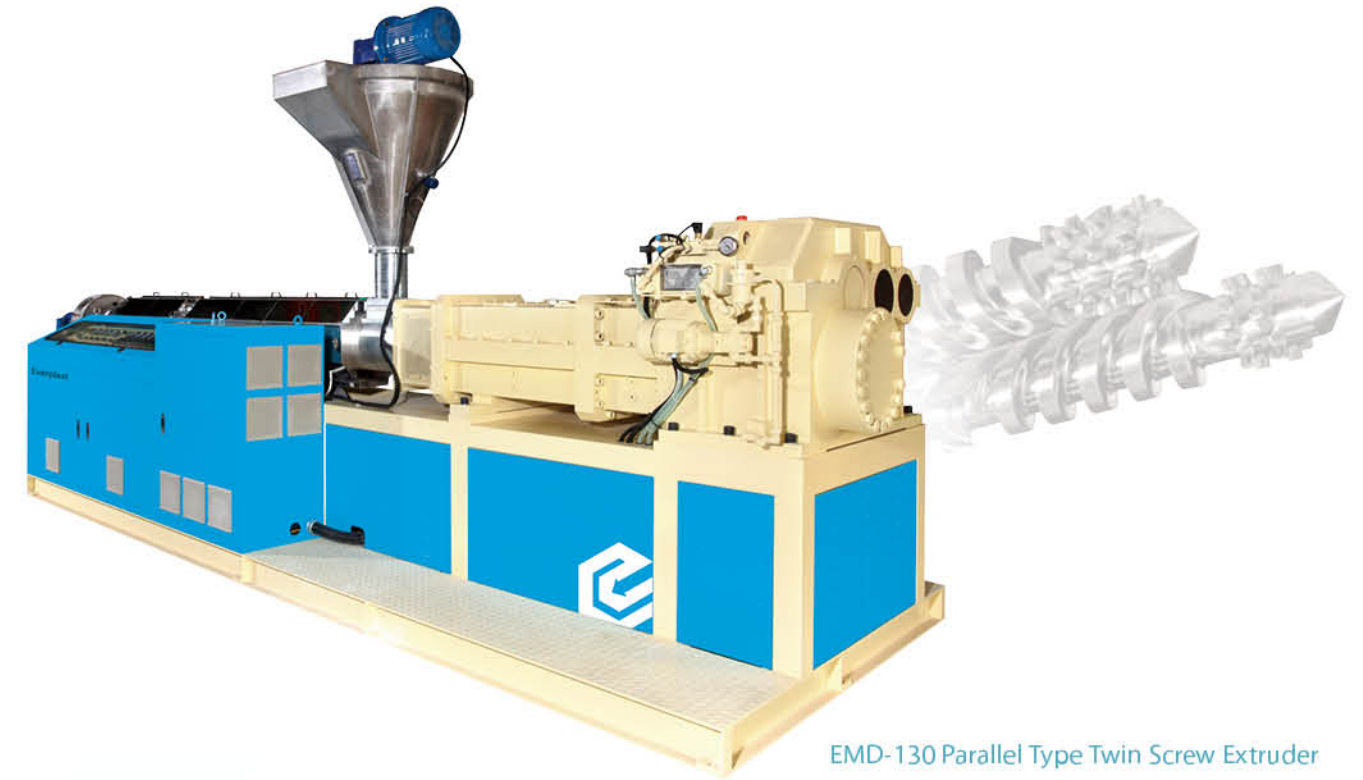

EMD-130 Parallel Type Twin Screw Extruder



SINGLE SCREW EXTRUDER



Vertical Co-Extruder



Horizontal Co-Extruder



EMS-60 Single Screw Extruder



EMS-65 Single Screw Extruder



EMS-85 Single Screw Extruder

CONICAL TWIN SCREW EXTRUDER



EMD-55C Conical Type Twin Screw Extruder



EMD-65C Conical Type Twin Screw Extruder



EMD-80C Conical Type Twin Screw Extruder

PARALLEL TWIN SCREW EXTRUDER



EMD-65 Parallel Type Twin Screw Extruder



EMD-90 Parallel Type Twin Screw Extruder

> CALIBRATION MACHINE AND DIE

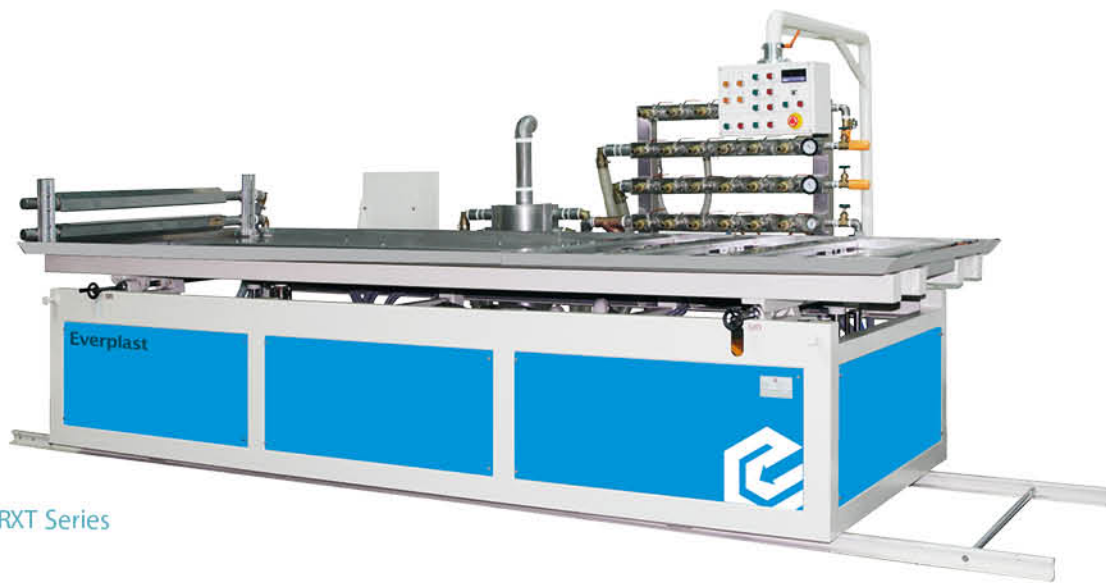

ERXT Series



Calibration Unit



ERT-6000XL Series



ERT-3000 Series



ERT-4500L Series



ERT-S-2500 Series



ERT-6000L Series



Utilizes vacuum pumps with ratings of 3 HP to 100 HP.
Cooling capacity of 30 KGS/HR to 500 KGS/HR.

Positions can be adjusted front and back or left and right. Front-back movements is done by a stepless inverter motor which can make either high speed or incremental adjustments. Water flowmeter cooling device is displayed to allow control of die temperatures and monitor temperature records. A specially designed die clamp frame allows vertical and horizontal adjustment to accept molds of all sizes. A phase control electrical protector guards against errors in vacuum pump rotation.

➤ HAUL-OFF MACHINE



ETXC-25 Series



ETC-30 Series Caterpillar



ETC-15 Series Caterpillar

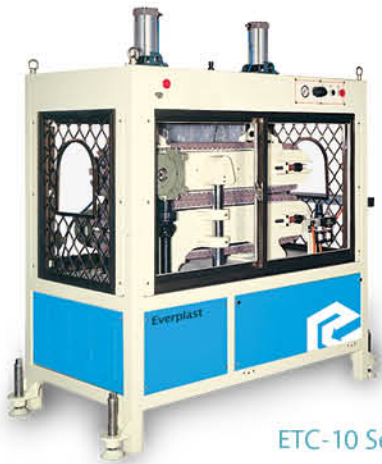

ETC-10 Series Caterpillar



ETXC-1000 Series



Roll Series



ETB-03 Series Belt

Unit pulling force for the various series ranges from 200KGS to 6000KGS.

Line speed is adjustable from 0.1M/MIN to 100 M/MIN, and high-sensitivity clamps effectively meet the needs of every type of products.

Auto pressure balance system responds to varying shapes of products to avoid production shutdowns when processing product sizes are changed.

Microcomputer counter can be used to set the length of products and count the quantities of products.

Design of the large Haul-off machines includes thick, hardened glass sliding doors which provide a clear view of the production process with a high degree of safety. They also facilitate easy maintenance and repair.

Compound tracks use UHMW-PE with outstanding wear resistance and minimal pollution, and rubber caterpillars are specially flush designed for easy replacement.



ETB-05 Series Belt



ETC-05-T Series Caterpillar

> CUTTING MACHINE

Cutting surface areas range from 100mm x 100mm of the ESC series to the 1200mm x 80mm of the EKC 1200 series, with varying designs to fit different cutting requirements.

>Specifications for the ESC series are:

Max. cutting speed:20 times/min
Cutting verticality:0.3/100mm

Cutting tolerance:+1mm
Blade speed:3400RPM

>Specifications for the EFC series are:

Max. cutting speed:35 times/min
Cutting verticality:0.3/100mm

Cutting tolerance:+0.2mm
Blade speed:3400RPM

>Specifications for the EKC series are:

Cutting tolerance:+0.2mm
Max. work area:(H)80mm x (W)1200mm



Air Type Cutter



ESC 14/16 Saw Cutter

The ESC series cutting machine uses the taper shaft of motor which can be fitted the saw without any key, during the high RPM the saw still keeps its balance to cut the products.



EKC Series



Servo Fly Cutter



EAC-3000S Series



Insert card type electric distribution system



Guillotine Type Cutter

> TOOLINGS

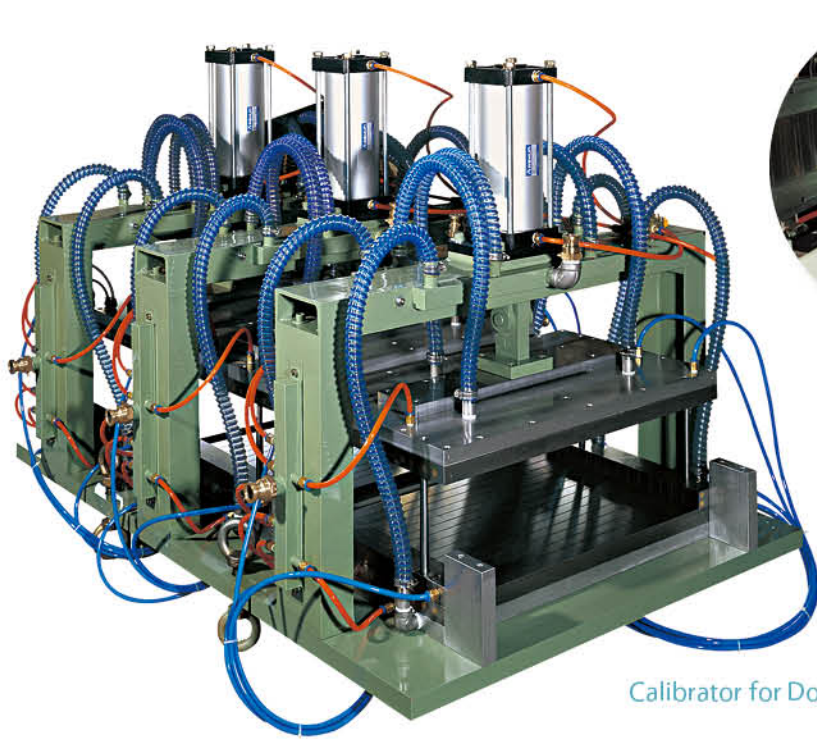

Calibrator for Door

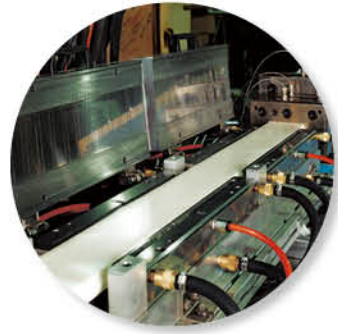

Die for Door

Trunk



Corrugated Sheet



EVERPLAST boasts 20 years of activity and experience in the manufacture of dies and calibrators for the extrusion of profile sections in PVC, PC, PE, PP, PS, ABS and other plastic materials. It furthermore specializes in the production of custom made machines and accessories for extrusion and co-extrusion.

EVERPLAST concentrates particularly on equipment for high production rate with excellent extruded profile quality thanks to the exclusive use of the most modern Cad Cam systems, high technology computerized machines, and operators with advanced skills and leading computer experience.

EVERPLAST produces equipment with single and multiple outlets for small as well as large size profiles in the following areas of application:

- > window, door
- > wall panel, cladding, ceiling and various constructional profiles
- > profiles for furniture
- > cable channels, conduit, tubes in PVC, PE, PP
- > co-extruded profiles for various materials



250 Ceiling



Double Ceiling



Door Panel



Double Extrusion



Trunk



Door Frame



PVC Foam



Window



PS foam Picture Frame

TOOLING

The profile process introduction for extruding machinery will show how extruded products meet the needs of the market as well as the special characteristics of the plastics that are used and the efficient assembling uses in the production process. Materials that can be used for extrusion include PVC, HDPE, LDPE, PE, PP, ABS, PS, PC and PMMA.

Products manufactured with these machines & dies include construction materials, toys and stationery, furniture and furnishings, medical supplies, lighting decoration and electrical accessories. Since its founding EVERPLAST Machinery's production line has turned out more than 1500 extrusion systems over the years. The suitability of these products and their competitiveness on the market are directly related to the characteristic of the plastic materials involved and the processes and machine fittings used to make the extrusion products.

WOOD PLASTIC COMPOSITE(W.P.C)



PVC FOAM & RIGID DOOR

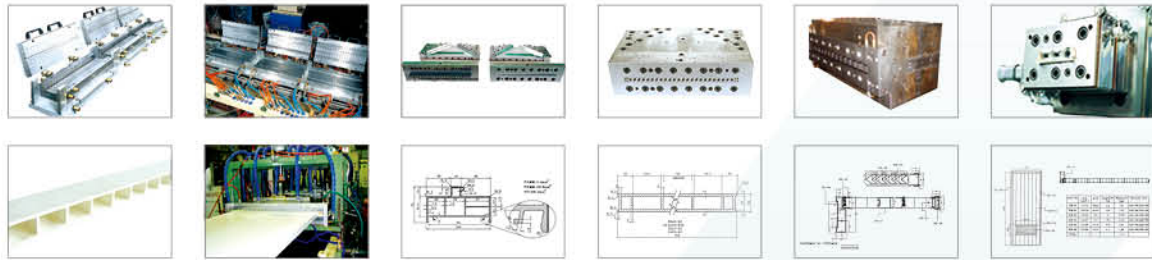

PVC WINDOWS

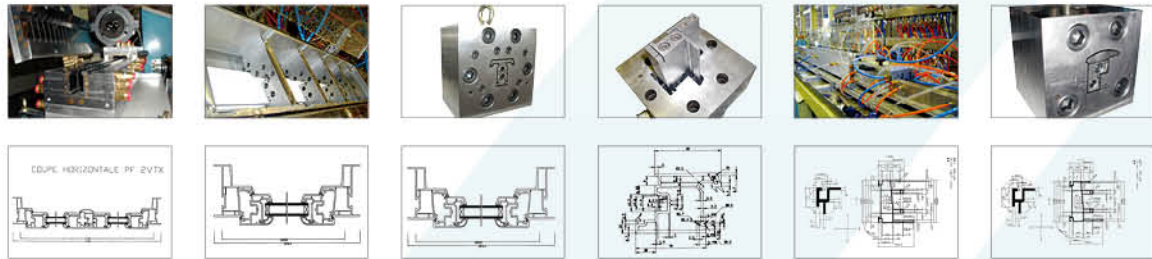

PVC FOAM & RIGID PANEL

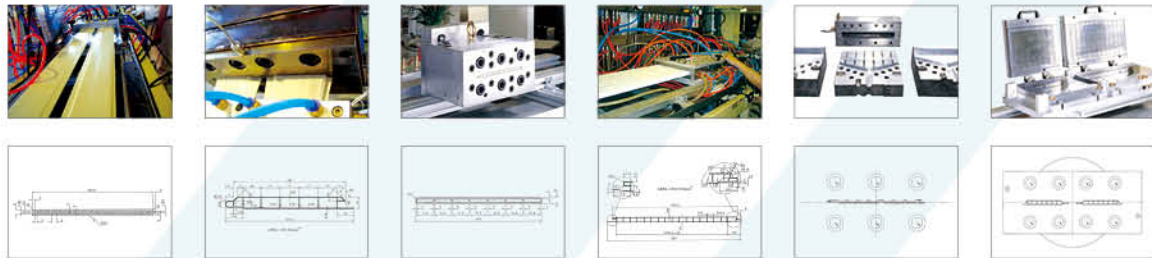

ASSEMBLING DOOR



TRUNKING

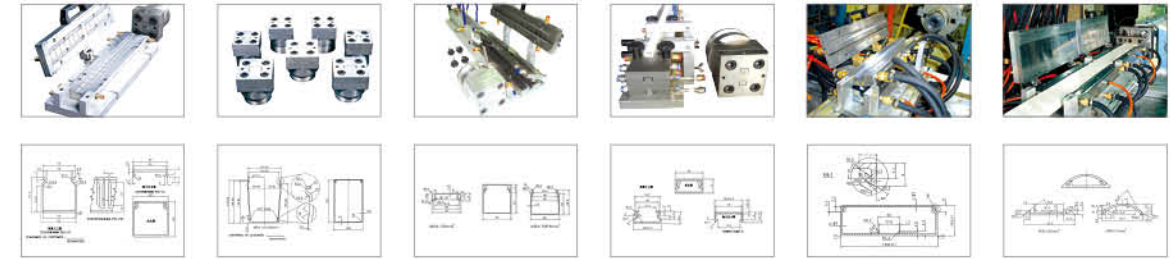

PS PICTURE FRAME

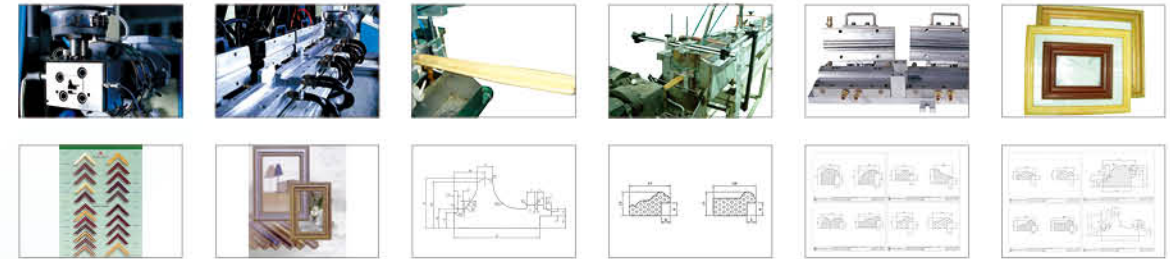

FOAM PROFILES

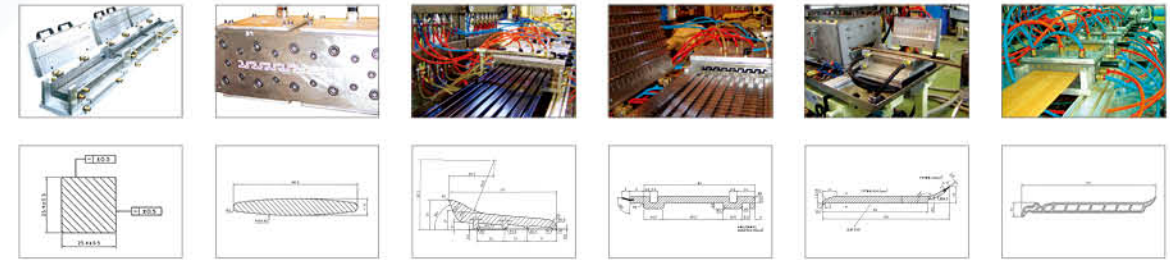

PVC / PE PIPE

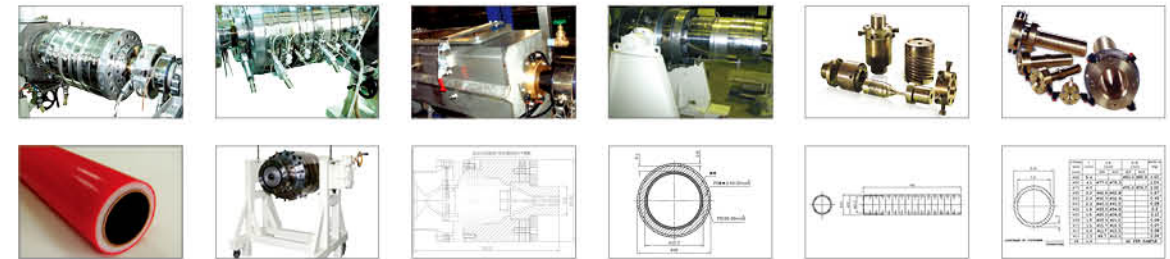

OTHERS

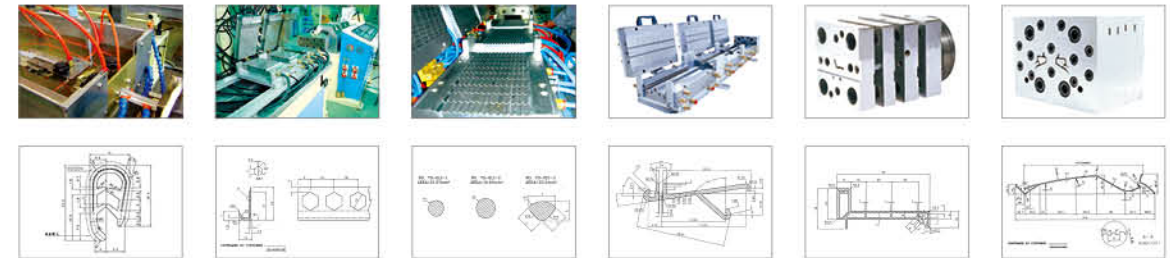

› PRINTING SYSTEM



3 Color Printing Machine



UV Dryer



UV Coating Unit

Over 25 years of continuous research in the field of coating technology, we are only providing our world class printing and coating equipments, but also achieving an outstanding acknowledgment over various paint materials. This enable us to constantly develop and upgrade series of high performance coating equipments, and each one will create the smooth, and brilliant coating surface for your specific requirement

Features:

- 1. INSTANT CURING: It eliminates the long waiting for drying up, and greatly shorten the process time through the entire finishing line.
- 2. DIRECT FIT TO COATING MACHINE: This unit may be fitted to roller coater or flow coater for direct curing after product is cut saves the troubles of moving of the workpiece.
- 3. This machine provides added surface rigidity and brilliant color.
- 4. APPLICATION VERSATILITY : U.V. paint coated products, e.g. panel furniture, components, steels, plates, construction material, ect, can be instantly cured.

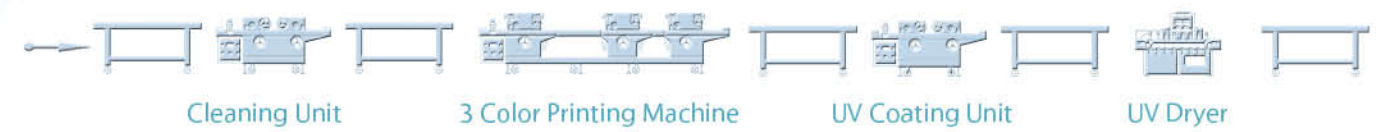

> PVC DOOR LINE



PANEL DIE HEAD

- Material : sus#420J2
- Multi-plate type for easy cleaning



TWIN EXTRUDER

- Parallel counter rotation type EMD-90
- Screw dia : ø90x2
- Output : 200~250 kg/hr for door panel
- Temp controller : PID + SCR or computer type.
- Cooling system for barrel : Air cooling oil cooling type.



FRAME DIE HEAD

- Material : sus#420J2
- Multi-plate type for easy cleaning.

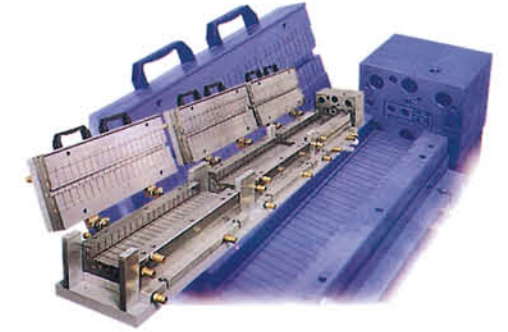

Computer Control
Is Available Upon Request

TWIN EXTRUDER

- Parallel counter rotation type EMD-65
- Screw dia : ø65mm
- Output : 80~150 kg/hr
- Temp controller : PID + SCR or computer type.
- Cooling system for barrel : Air cooling oil cooling type.

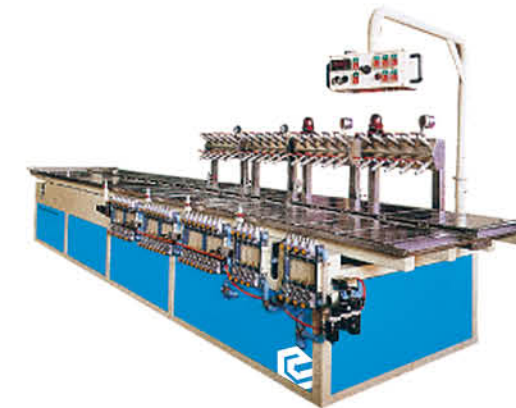

CALIBRATION

- Type of calibration:ERXT-800 / ERXT-1000 / ERXT-1200
- Vacuum pump: 30+30+20+20 4units
- Products width : 700mm / 800mm / 1000mm
- Positions can be adjusted up and down, left and right, forward-back movements is done by a stepless inverter motor

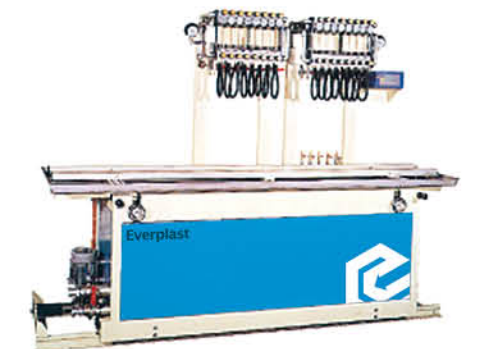

CALIBRATION

- Type of calibration:ERT-3000/ ERT-3000X / ERT-3000L
- Vacuum pump: 5HP × 1set / 5HP × 2sets / 5HP × 3sets
- Products width : MAX.400mm
- Positions can be adjusted up and down, left and right, forward-back movements is done by a stepless inverter motor

> PVC DOOR



HAUL-OFF M/C

- Type:ETXC-800 / ETXC-1000 / ETXC-1200
- Pulling force is about 58000N
- Auto-pressure balance system responds to varying shape of products to avoid production shutdowns when processing product sizes are changed.
- Micro computer counter can be used to set the length of products and pieces counting.
- Products width : 800mm / 1000mm / 1200mm

HAUL-OFF M/C

- Type:ETXC-800 / ETXC-1000 / ETXC-1200
- Pulling force is about 58000N
- Auto-pressure balance system responds to varying shape of products to avoid production shutdowns when processing product sizes are changed.
- Micro computer counter can be used to set the length of products and pieces counting.
- Products width : 800mm / 1000mm / 1200mm



CUTTER

- Type:EKC-700 / EKC-800 / EKC-1000
- Products Width:700mm / 800mm / 1000mm
- Knife Type:dustless

CUTTER

- Type:ESC-14 / ESC-16. Saw cutting type.
- Max.cutting width:200mm
- Taper shaft of motor is no need any key to fix the saw during the high RPM and can get very smooth products surface.



STACKER

- Automatic Stacker Type.Man-power less.
- Special Design To Carry PVC Panel To Prevent Scrape The Surface Of Panel.

>PVC Door Panel Whole Plant

Specification	Type	PVC Door Panel			PVC Door Frame	LJBin/IBin
Size(mm)		600 / 700 / 760 / 815 / 900			100 / 160	
Extruder	Type	EMD-110 Parallel twin screw	EMD-110 Parallel twin screw	EMD-65 Parallel twin screw	EMD-45 Single screw	
	Screw dia(MM)	φ110×2	φ90×2	φ65×2	φ45×2	
	L/D	24	24	24	24	
	Motor(KW)	75 / 100	60 / 75	30	15	
	Output(Kg/hr)	350	250	80~120	30	
Die Head & Sizing Mold	Material	sus#420J2	sus#420J2	sus#420J2	sus#420J2	
	Die Head	Mult-Plate	Mult-Plate	Mult-Plate	Mult-Plate	
	Sizing Mold	3 or 4 sets	3 sets	2 or 3 sets	1 set	
Calibration	Type	ERXT-600	ERXT-800	ERXT-1000	ERT-3000X	ERT-3000
	MAX.Width(MM)	600	800	1000	400	400
	Vacuum Unit(NO)	4sets	4sets	4sets	2sets	1sets
	Vacuum Pump(HP)	10×4	10×2+7.5×2	10×2+7.5×2	5×2	5
	Water Flowmeter	8×3 in 8×3 out	8×3 in 8×3 out	8×3 in 8×3 out	8×2 in 8×2 out	8 in 8 out
Haul-Off	Type	ETXC-600	ETXC-800	ETXC-1000	ETC-1506	ETC-0506
	MAX.Width(MM)	600	800	1000	200	120
	Pulling Force (N)	58000	58000	58000	17000	3400
	Drive Motor(HP)	2×2	3×2	5×2 / 7.5×2	5	2
Cutter	Type	EKC-600 (Dustless)	EKC-800 (Dustless)	EKC-1000 (Dustless)	ESC-14 Saw	ESC-14 Saw
	MAX.Cutting Width(MM)	600	800	1000	200	200
	MAX.Cutting Hight(MM)	Max.80	Max.80	Max.80	φ160	100
	Motor(HP)	3	3	3	1	1

Specifications are subject to change without notice.

>Twin Screw Extruder

Specification	Type	Twin Screw Extruder												
		Parallel Twin Screw Extruder					Concial Twin Screw Extruder							
		EMD-55	EMD-65	EMD-90	EMD-110	EMD-130	EMD-55C	EMD-65C	EMD-80C	EMD-92C				
Screw Length (L/D)		25/28	25/28	25/28	22	22	22	22	22	22				
Screw Diameter (MM)		55×2	65×2	90×2	110×2	130×2	55/112	65/132	80/156	92/188				
Screw Speed (R.P.M)		60	60	44	38	30	40	40	40	40				
Dirve Motor Power (HP)		20	--	30	60	75	90	100	125	150				
Cylinder Heating (KW)		18	--	22	30	38	42	50	80	90				
Flange Heating (KW)		4	5	6	7.5	8.5	2	4	4	8				
Cylinder Cooling Power (KW)		0.6	0.6	0.6	1.2	1.2	1.5	1.5	1.5	2				
Installed Electric Power (KW)		38/53	40/51	82/102	119/133	175/192	48	67	102	160				
Number Of Die Heating Zones		2+3	2+3	2+4	2+4	2+4	2	4	8	10				
Number Of Cylinder Heating Zones		4	4	4	4	5	4	4	4	4				
Hopper Sizes (KG)		75	100	150	200	200	75	100	150	150				
Center Helght (MM)		1100	1100	1100	1100	1100	1100	1100	1100	1100				
Weight (KG)		1600	2000	3000	4100	5600	2300	3600	3900	4800				
M.AX Output (KG/HR)	HDPE (PIPE)	--	--	--	--	--	--	--	--	--				
	PVC Soft	--	--	--	--	--	--	--	--	--				
	PVC Hard	60	80	120	160	400	500	600	700	800	1000	60~120	80~150	250~360

Specifications are subject to change without notice.

> SPECIFICATION

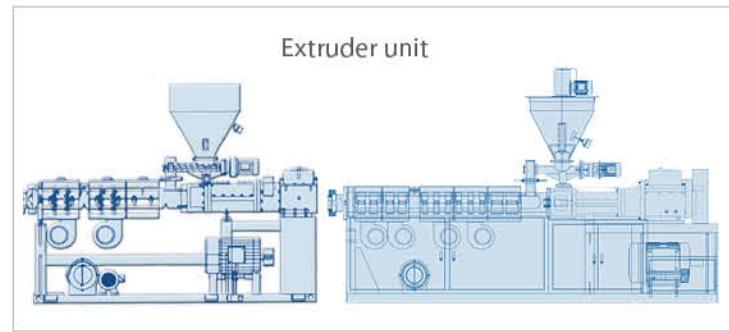

EMS-Single EMD-Twin

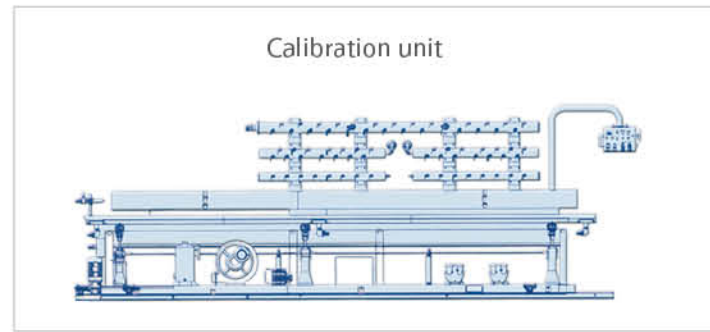

ERT-Calibrator

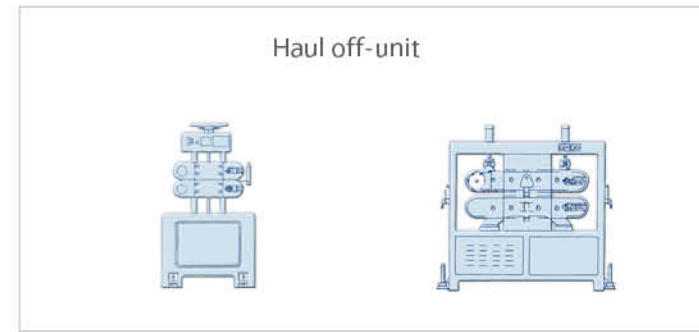

ETB ETC

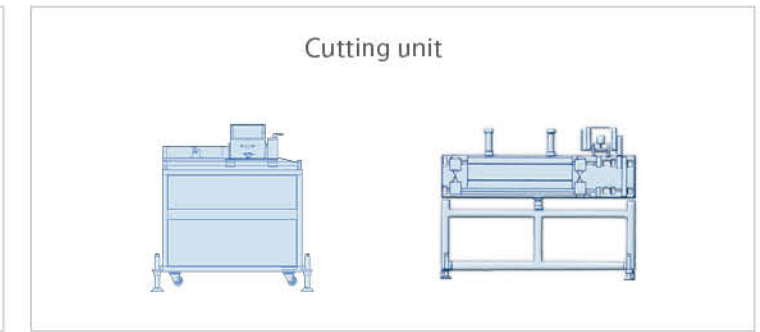

ESC EKC

>Figure of Extruder

Specification	Type	Single Screw Extruder													
		EMS-45		EMS-55		EMS-65		EMS-85		EMS-100		EMS-125		EMS-150	
Screw Length (L/D)		24/28		24/28		24/28		24/28		24/28		24		24	
Screw Diameter (MM)		45		55		65		85		100		125		150	
Screw Speed (R.P.M)		60	120	60	120	60	120	50	120	50	120	50		45	
Drive Motor Power (HP)		15	30	20	30	30	75	40	150	50	200	100		125	
Cylinder Heating (KW)		7.5		10		12		14		15		20		25	
Flange Heating (KW)		0.5		0.6		0.7		1		1		1.5		2	
Cylinder Cooling Power(KW)		0.05×3		0.05×3		0.05×3		0.1×3		0.1×4		0.2×3		0.2×3	
Installed Electric Power(KW)		22/34		30/68		36/92		47/160		88/238		133		180	
Number Of Die Heating Zones		2		3		3		3		4		5		6	
Number Of Cylinder Heating Zones		3		3		3		4		5		7		8	
Hopper Sizes (KG)		50		50		50		100		100		150		150	
Center Height (MM)		1100		1100		1100		1100		1100		1100		1100	
Weight (KG)		850		950		1100		1600		2200		2500		3000	
MAX.Output(KG/H)	HDPE Pipe	70		100		150		350		500					
	PVC Profile	25		40		70		100		150		200		250	

>Figure of Haul-Off

Specification	Type	ETB-05		ETB-10		ETC-05		ETC-10		ETC-15		ETC-20		ETXC25		ETXC30	
		Belt				Caterpillar				Wide Caterpillar							
Effective Clamping Length (MM)		350	750	350	750	1300	1800	2300	2800								
Effective Clamping Width (MM)		150	196	120	200	200	200	200-1500	200-1500								
Effective Clamping Height (MM)		110	150	110	150	150	150	150	150								
MAX. Pulling Force (N)		3400	6000	3400	6000	17000	35000	58000	58000								
Drive Motor (HP)		2	3	2	3	3×2	3×2	3×2	3×2								
Installed Electric Power (KW)		2	3	2	3	7	7	7	7								
MAX.Line Speed (M/MIN) Available		50	20	12	9	9	1-6	1-6	1-6								
Weight (KG)		550	1200	600	1000	1600	2700	2500-5000	4000-7000								

>Figure of Vacuum-Calibration

Specification	Type	ERT3000	ERT3000X	ERT3000L	ERT4500L	ERT6000L	ERXT600	ERXT800	ERXT1000	ERXT1200
Adjustable Length For Back And Forwards		750	750	750	750	750	1000	1000	1000	1000
Adjustable Length For Right And Left(MM)		50	50	50	50	50	50	50	50	50
Adjustable Length For Up And Down(MM)		100	100	100	100	100	100	100	100	100
Length Of Calibration Table(MM)		3000	3000	3000	4500	6000	4000	4000	4000	6000
M.A.X Products Width(MM)		300	300	300	300	300	600	800	1000	1200
Number Of Vacuum Pump		1	2	3	3	2	1	4	1	3
Vacuum Pump(HP)		5	5	5	5	5	7.5	10	20	10
Drainage Pump(HP)		1	1	1	1	2	2	2	2	2
Number Of Water Flow Valve		8	16	24	32	32	32	32	32	32
M.A.X Exhaust Volume (M3/MIN)		1.9	3.8	5.7	7.6	7.6	14	20	32	40
Installed Electric Power(KW)		5.5	9.5	13.5	17.5	17.5	35	50	70	85
Inlet Pipe Diameter (INCH)		1.5	2	2	2	2	2	2	2	2
Drain Outlet Pipe Diameter(INCH)		1.5	2	2	2	2	2	2	2	2
Weight (KG)		500	600	700	1200	1800	2000	2400	2800	3500

>Figure of Saws

Specification	Type	For Profile				For Door Panel & Plank		
		ESC14	ESC16	ESC18	ESC20	EKC700	EKC1000	EKC1200
M.A.X Cutting Width(MM)		200	280	330	400	700	1000	1200
M.A.X Cutting Height(MM)		90	115	155	180	80	80	80
Cutting Motor Power(KW)		0.5	0.5	2	2	2	2	2
Travel Of Saw Carriage(MM)		355	405	455	505	355	355	355
Installed Electric Power(KW)		2	2	2	2	2	2	2
Weight (KG)		300	320	400	420	1200	1700	2000

Specifications are subject to change without notice.

➤ **MAIN PROFILE EXTRUSION LINES AVAILABLE:**

- 1.WOOD PLASTIC COMPOSITE
- 2.PVC FOAM PROFILES
- 3.PVC WINDOW / DOOR COMPLETE PLANT
- 4.PVC RIGID / FLEXIBLE PROFILES
- 5.PVC TRUNKING COMPLETE PLANT
- 6.PS FOAM PICTURE FRAME AND BUILDING / DECORATION PROFILE
7. PC LAMP / PC PROFILE
- 8.ALL KINDS OF PROFILE DIE

➤ **MAIN PIPE EXTRUSION LINES AVAILABLE:**

- 1.HDPE/LDPE PIPE RANGE TO MAX.Ø1200 m/m
- 2.PVC PIPE RANGE TO MAX.Ø1200 m/m
- 3.LDPE COSMETIC TUBE
- 4.PU PRECISION TUBE
- 5.HDPE STEEL PIPE COATING SYSTEM
- 6.PC TRANSPARENT TUBE
- 7.FLEXIBLE PVC TUBE AND REINFORCED HOSE
- 8.RIGID / SOFT PVC SUCTION HOSE
- 9.PVC MEDICAL TUBE
- 10.PVC / PE DIE UPTO Ø1200 m/m

➤ **ACCESSORIES:**

- 1.MIXER AND COOLER
- 2.PRINTING MACHINE



Everplast Machinery Co.,Ltd

Office:11F., No. 106, Yongle St., Luzhou Dist., New Taipei City 247, Taiwan
TEL.+886-2-2289-7271 FAX.+886-2-2289-7282
Factory:No.151, Yonke S. Rd., Yonkang Dist., Tainan City 710, Taiwan
TEL.+886-6-201-4846 FAX.+886-6-201-4290
E-mail:everstar@mail.everplast.net
www.everplast.com.tw